

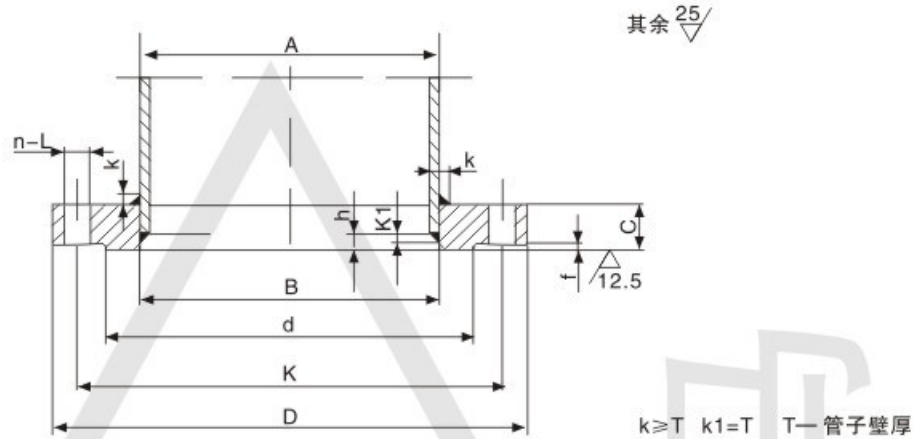

船用法兰 GB/T 2506-2005 (本标准代替GB/T 2506-1989)



单位 (mm)

公称压力 PN (MPa)	公称通径 DN	钢管外径A		连接尺寸			密封面			端距 h	螺栓螺纹及通孔			重 重 kg	
		系列1	系列2	D	K	B	C	d	f		Th	L	n		
0.25 0.6	10	17.2	17	75	50	18	12	33	2	4	M10	11	4	4	0.31
	15	21.3	22	80	55	23		38							0.35
	20	26.9	27	90	65	28	14	48							0.53
	25	33.7	34	100	75	35		58							0.64
	32	42.4	42	120	90	43	16	69		1.08					
	40	48.3	48	130	100	49		78		1.19					
	50	60.3	60	140	110	61		88		1.31					
	65	76.1	76	160	130	77.5		108		1.64					
	80	88.9	89	190	150	90.5	18	124		2.53					
	100	114.3	114	210	170	116		144		3.71					
	125	139.7	140	240	200	142	20	174		3.90					
	150	168.3	168	265	225	170		199		4.32					
	175	193.7	194	295	255	196	22	232		5.82					
	200	219.1	219	320	280	221.5		254		6.31					
	225	-	245	345	305	248	24	282		6.85					
	250	273		375	335	276.5		309		8.43					
	300	323.9	325	440	395	328.5	26	363		10.60					
	350	355.6	377	490	445	360		381		413	15.99	13.50			
	400	406.4	426	540	495	410	430	28		463	19.13	16.22			
	450	457	480	595	550	462	485	30		518	23.61	19.58			
500	508	530	645	600	513	535	32	568	27.21	22.67					
600	610	630	755	705	615	635	36	667	38.19	32.64					
0.25	700	711	720	860	810	715	36	772	9	M24	26	20	43.16	40.28	
	800	813	820	975	920	817	38	878	10			24	56.40	53.71	
	900	914	920	1075	1020	918	924	40					978	66.36	63.64
	1000	1016	1020	1175	1120	1020	1024	42	1078	11	M27	30	28	75.61	73.49
	1200	1220		1375	1320	1224	44	1295	32					92.95	
	1400	1420		1575	1520	1424	48	1510	36					119.2	
	1600	1620		1790	1730	1624	51	1710	40					159.3	
	1800	1820		1990	1930	1824	54	1918	44	190.1					
	2000	2020		2190	2130	2024	58	2125	48	227.3					



单位 (mm)

公称压力 PN (MPa)	公称通径 DN	钢管外径A		连接尺寸				密封面			端距 h	螺栓螺纹及通孔			重 重 kg	
		系列1	系列2	D	K	B		C	d	f		Th	L	n		
0.6	700	711	720	860	810	715	724	40	772	5	9	M24	26	24	48.39	45.20
	800	813	820	975	920	817	824	44	878		10	M27	30		66.07	62.95
	900	914	920	1075	1020	918	924	48	978		11				28	80.73
	1000	1016	1020	1175	1120	1020	1024	52	1078		12	M30	33	32	95.03	92.41
	1200	1220		1405	1340	1224		60	1295		13			36	234.0	
	1400	1420		1630	1560	1424		68	1510		M33	36	40	297.6		
	1600	1620		1830	1760	1624		76	1710				44	394.7		
	1800	1820		2045	1970	1824		84	1918		M36	39	44	394.7		
1.0 1.6	10	17.2	17	90	60	18		14	41	2	4	M12	14	4	0.53	
	15	21.3	22	95	65	23			46						0.59	
	20	26.9	27	105	75	28		16	56						0.84	
	25	33.7	34	115	85	35			65						1.09	
	32	42.4	42	140	100	43		18	76		1.81					
	40	48.3	48	150	110	49			84		2.05					
	50	60.3	60	165	125	61		20	99		2.53					
	65	76.1	76	185	145	77.5			118		M16	18	2.96			
	80	88.9	89	200	160	90.5		132	3.36							
	100	114.3	114	220	180	116		22	156		4.12					
	125	139.7	140	250	210	142			184		M20	22	5.09			
	150	168.3	168	285	240	170		24	211				6.74			
	175	193.7	194	315	270	196			242		7	7.72				
	1.0	200	219.1	219	340	295	221.5		24		266	2	6	M20	22	8
225		-	245	370	325	248		295		9.73						
250		273		395	350	276.5		26	319	10.94						
300		323.9	325	445	400	328.5		28	370	13.26						
350		355.6	377	505	460	360	381	30	429	16	20.98		18.11			
400		406.5	426	565	515	410	430	32	480		26.72		23.40			
450		457	480	615	565	462	485	35	530	M24	26		31.61	26.91		
500		508	530	670	620	513	535	38	582				20	39.15	33.75	
600		610	630	780	725	615	635	42	682	9	M27		30	53.39	46.92	
1.6	200	219.1	219	340	295	221.5		26	266	2	7	M20	22	12	9.25	
	225	-	245	370	325	248		27	295						11.04	
	250	273		405	355	276.5		28	319						13.05	
	300	323.9	325	460	410	328.5		32	370		8	M24	26	18.03		
	350	355.6	377	520	470	360	381	35	429					16	27.12	23.76
	400	406.4	426	580	525	410	430	38	480		34.93	30.99				
	450	457	480	640	585	462	485	42	548		M27	30	45.01	39.37		
	500	508	530	715	650	513	535	46	609				20	62.71	56.17	
	600	610	630	840	770	615	635	52	720		11	M33	36	94.65	86.64	

注 1、第一系列的管子外径尺寸为国际通用尺寸；第二系列的管子外径尺寸为我国通用尺寸。
注 2、k₁大于等于h时，h值取k₁+1



船用法兰 GB 573-65

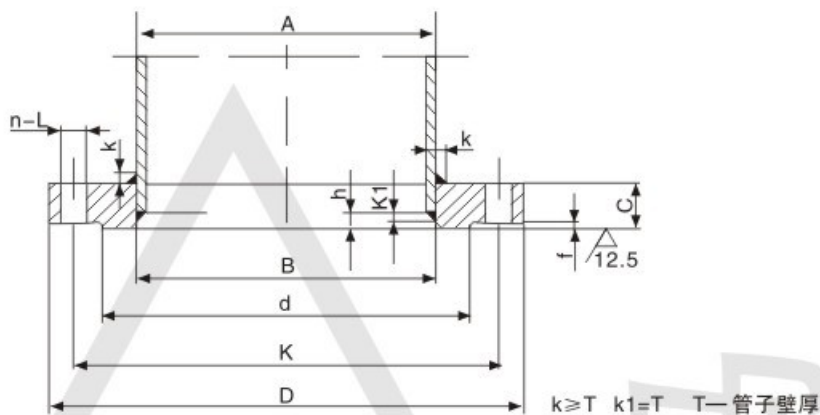

单位 (mm)

公称压力 PN (MPa)	公称通径 DN	管子外径与 法兰内径 B	法兰				螺栓			
			外径 D	螺栓孔 中心圆 直径 K	密封面 外径 d	厚度 C	螺栓孔 直径 L	数量 (个) n	直径 (螺纹) m	
≤1.6	15	21.2	85	55	35	12	13	4	M12	
	20	27	95	68	48	13				
	25	32	105	73	56	14				
	≤1.0	32	42	115	83	64	15	6	M14	
		40	49	125	93	74				
		50	61	135	103	84	14	6	M14	
65		78	155	123	104	8				
80		91	170	138	118	10				
0.6	100	小孔110/大孔115	190	158	138	15	15	12	M14	
	125	小孔135/大孔142	215	183	164			14		
	150	小孔161/大孔170	240	208	190	16	17	14	M16	
	(175)	194	270	238	221			12		M14
	200	221	295	264	247			16		
	1.0	(225)	245	335	297	276	19	21	16	M20
		250	273	365	327	306			18	
		300	325	430	386	360	21	21	20	M20
350		377	480	436	410	18				
400		426	530	486	460	24	26	16	M24	
450		478	580	536	512			14		
500		小孔515/大孔529	635	591	567	25	26	18	M24	
(175)		194	285	248	226			12		
200	221	310	273	250	17	17	14	M16		
(225)	245	340	302	280			16			
1.0	250	273	380	336	310	20	21	16	M20	
	300	325	435	391	364			18		
	350	377	485	441	414	24	26	16	M24	
	400	426	545	496	466			18		
	450	478	600	551	520	25	26	20	M24	
	500	小孔515/大孔529	650	601	573			20		